

# CADENCE AWR DESIGN MAGAZINE

A quarterly publication highlighting AWR RF/microwave design software for product development through white papers, application notes, and customer success stories.

Volume 20.1

## Cover Story

Microwave Journal Interviews Glen Clark, Cadence VP of R&D, on the Recent AWR Acquisition

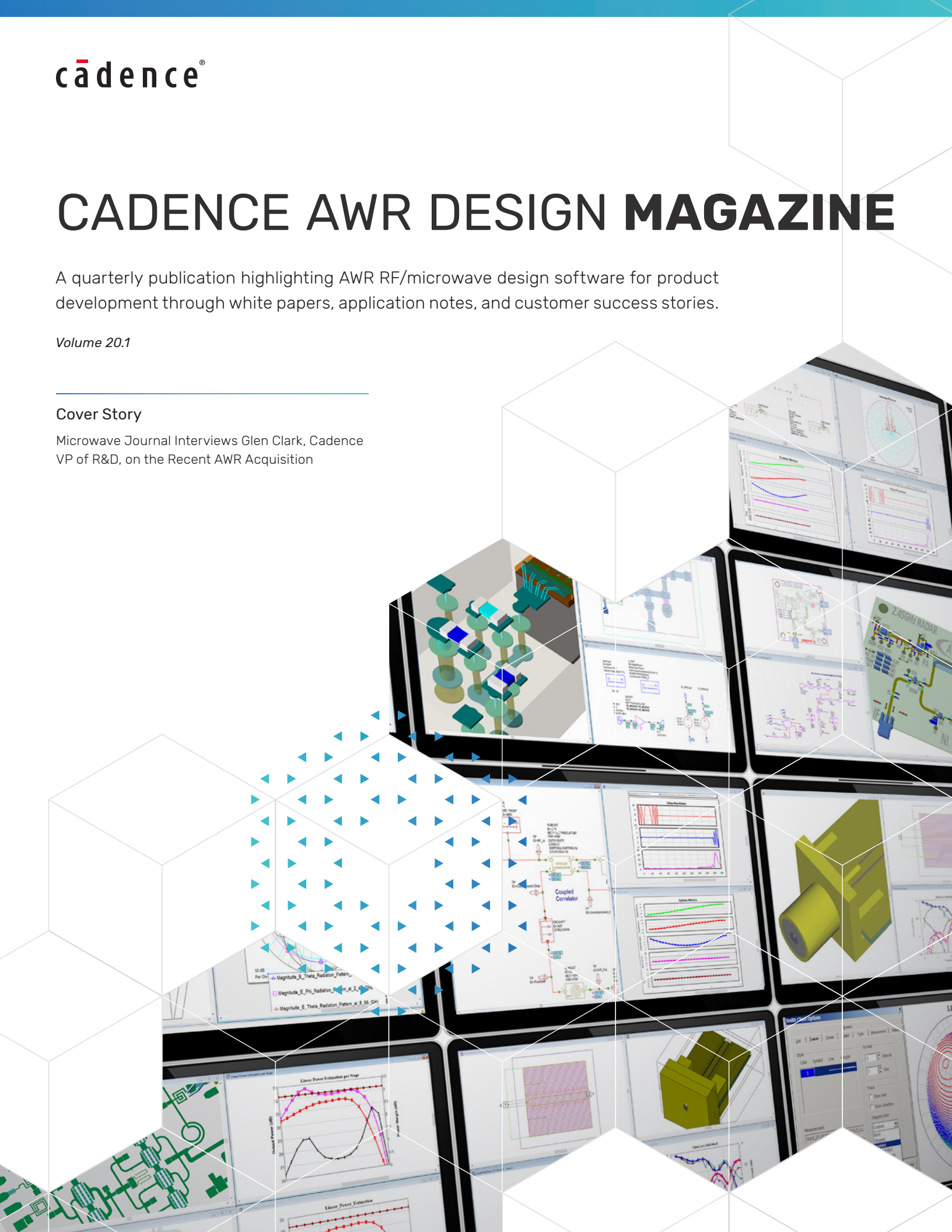

- 2

**COVER STORY**

Glen Clark on the AWR Acquisition
- 3

**CUSTOMER SUCCESS**

Wavice Research Engineer Designs S-Band IMFET
- 5

**APPLICATION NOTE**

New Method for X-Band Bandpass Filter Design
- 7

**RESOURCE SPOTLIGHT**

E-Learning Portal: Visual System Simulator
- 9

**APPLICATION NOTE**

PCB Design Leveraging RF/Microwave Expertise
- 11

**WHITE PAPER PREVIEW**

Design of a Complete RF Downconverter Module
- 13

**CUSTOMER SUCCESS**

Anritsu Designs G-Band Frequency Tripler

## Glen Clark on the AWR Acquisition

Glen Clark, Cadence VP of R&D for Customer ICs and PCBs, recently talked about the AWR® acquisition in an exclusive Q&A with Microwave Journal. Here are some of the highlights of the discussion.

### What motivated Cadence to acquire AWR?

Historically, we've been incredibly strong in RF design on silicon (Si) but had more limited offerings for RF design in III-V technologies or microwave/mmWave design. As we worked with the AWR team to tightly integrate AWR AXIEM® 3D Planar EM Analysis into the Cadence® Virtuoso® environment, we saw that a similar integration of other AWR simulation technologies into the Cadence tool suite provided a great opportunity for us and for our customers. Thus, the acquisition made complete sense, and we're happy to be working as one team now.

### How are you integrating AWR products and people into Cadence? Will AWR remain a focused product area?

We are fully committed to the AWR product suite, and it will remain a focused product area for us. In fact, when we were doing our due diligence on the acquisition evaluation, we heard a consistent message that not only does AWR have great design tools, but they also do a superior job of supporting customers. We want to ensure that customers continue to get this excellent level of service.

Additionally, we plan to leverage the AWR technology throughout the Cadence product lines, and we see a number of opportunities where we can support our customers optimally with a tight integration between AWR and existing Cadence products.

### How will the two worldwide sales and support teams operate going forward?

With respect to the sales and support teams, while I can't comment on the specifics of how the teams will operate, I can say a couple of things:

- ▶ We know that RF/microwave designers require very specialized support, and AWR brings us a wealth of sales and support talent that enhances the expertise of our field team and its ability to support customers.
- ▶ We're well underway with the integration of our products and people and, as an R&D organization, we're lucky to have the best sales and support team in the industry.



*We plan to leverage the AWR technology throughout the Cadence product lines, and we see a number of opportunities where we can support our customers optimally with a tight integration between AWR and existing Cadence products.*

Glen Clark, Cadence



How do you envision the AWR software platform meshing with Cadence tools? What makes sense to integrate and what will stand alone? Is there a long-term plan for deeper integration?

When we look at the challenges our customers are facing, we certainly see a need for a tighter integration across our product portfolio. Accordingly, while we continue to actively develop the AWR product suite, we've also identified a number of opportunities where tighter integration makes sense. There are ongoing development efforts for both near- and longer-term solutions, and we'll be sharing more details when we finalize our plans.

What is Cadence's "Intelligent System Design" strategy, and how does AWR fit in or expand that strategy?

The Cadence Intelligent System Design™ strategy enables our customers to achieve greater efficiencies and design excellence through the use of our broad portfolio of solutions. We recognize that most end users rarely buy just a chip, rather something in which the chip is a critical component. We know we need to extend our focus beyond chip design to address how that chip is ultimately used. And further, with the explosion of data, there are many more opportunities for our customers to make their products more intelligent.

Cadence and AWR have great synergies. Designers need to address many challenging RF/microwave integration problems across a wide range of applications, and that's in the DNA of the AWR products and team.

What inspires the work you do?

When I think about the mentors I've had in my life, they've all demonstrated a strong commitment to their "job," whether that was at home or at work. They executed with great integrity and treated everyone with the utmost respect, displaying an intense desire to help others achieve their goals. I try to exemplify these traits as well and, at work, that means doing whatever my team and I can to ensure our customers tape out successfully and on time, every time.

We are passionate about customer success, and it drives every decision we make. This has been true for the Virtuoso and Allegro™ teams for a long time, and it's very true of the AWR team, as well. I think this shared culture has been critically important in making our integration seamless.



*We are passionate about customer success, and it drives every decision we make. This has been true for the Virtuoso and Allegro teams for a long time, and it's very true of the AWR team, as well. I think this shared culture has been critically important in making our integration seamless.*

Glen Clark, Cadence

The complete interview is available at [microwavejournal.com/articles/33716](http://microwavejournal.com/articles/33716).

## CUSTOMER SUCCESS

### Wavice Research Engineer Designs S-Band IMFET

Long-range radar systems with solid-state power amplifiers (PAs) often require high-power output, and as there is limited installation space, the device must also be very small in size. Monolithic microwave integrated circuits (MMICs) are considered the best solution for reducing the size of PAs.



*AWR software is intuitive, which reduced my design time while delivering high accuracy," said Oh. "In particular, the tuning and optimization features are advantageous for assigning variables to view performance trends.*

Kwanjin Oh, Wavice Inc.

However, the development cost of MMICs can be extremely high when used in low- to medium-volume applications such as defense. Wavice Inc designer Kwanjin Oh used the Cadence AWR Microwave Office® circuit simulator within the Cadence AWR Design Environment® platform to design an internally matching field-effect transistor (IMFET) that enabled a reduction in the size of the PA by more than 10 times. Matching the source and drain impedances was straightforward and the load-pull analysis, tuning, and optimization features in the software significantly reduced design time as well.

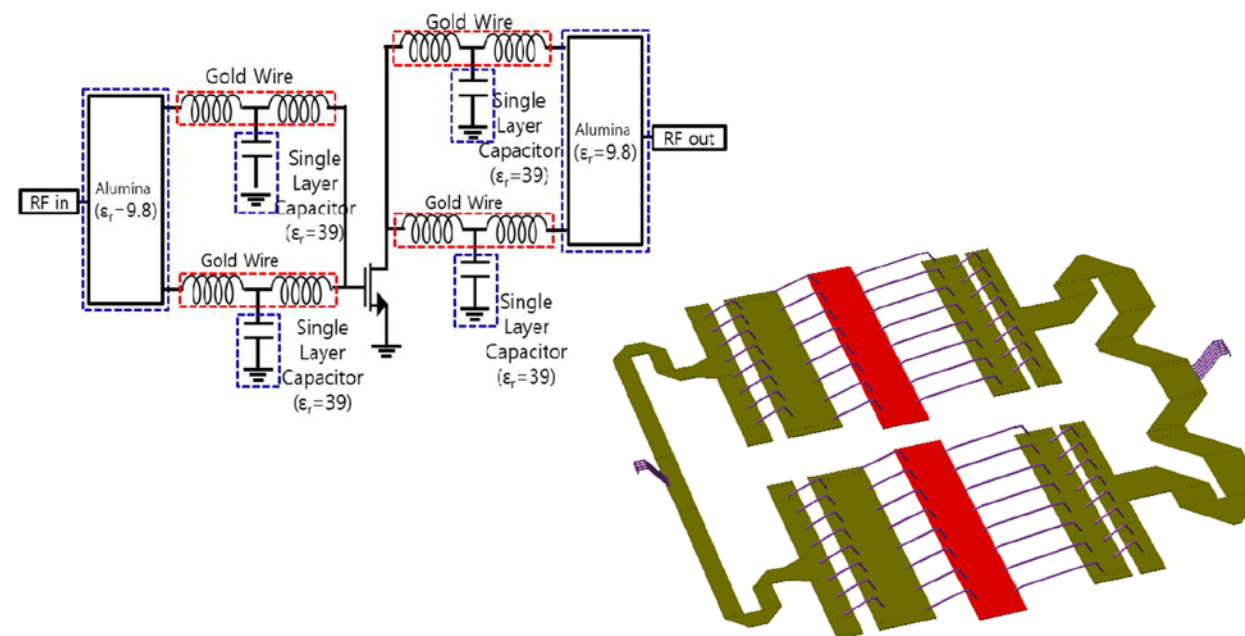

To read the full story, visit [awr.com/customer-stories/wavice-inc](http://awr.com/customer-stories/wavice-inc).

# New Method for X-Band Bandpass Filter Design

Microwave bandpass filters (BPFs) are the fundamental component used in many RF/microwave applications to eliminate interference from signals operating at nearby frequencies. This application note presents a straightforward and largely nonmathematical method for designing an edge-coupled, bandpass filter for X-band operations (8.4 - 9.3GHz) with a combination of filter synthesis, closed-form edge-coupled transmission-line models, and EM analysis using the AWR Microwave Office circuit simulator within AWR Design Environment software.

A miniature X-band, edge-coupled microstrip bandpass filter design example demonstrates this flow. The filter was implemented using edge-coupled microstrip lines on a Rogers RO4003 substrate material with  $\epsilon_r = 3.66$  and  $H = 8$  mil. The temperature coefficient of dielectric constant was among the lowest of any circuit board material, and the dielectric constant was stable over a broad frequency range, specifically at X-band frequencies. The simulated results showed good filter response characteristics with the passband insertion loss approximately 5 dB and return loss greater than 12 dB over the pass bandwidth of 900MHz.

## Bandpass Filter Construction

A BPF can be constructed from resonant structures, such as a waveguide cavity or open-circuit transmission lines (i.e., stubs). An important parameter in filter design considerations is the fractional bandwidth, which is defined as the ratio of the passband bandwidth to the geometric center frequency. The inverse of this quantity is called the Q-factor.

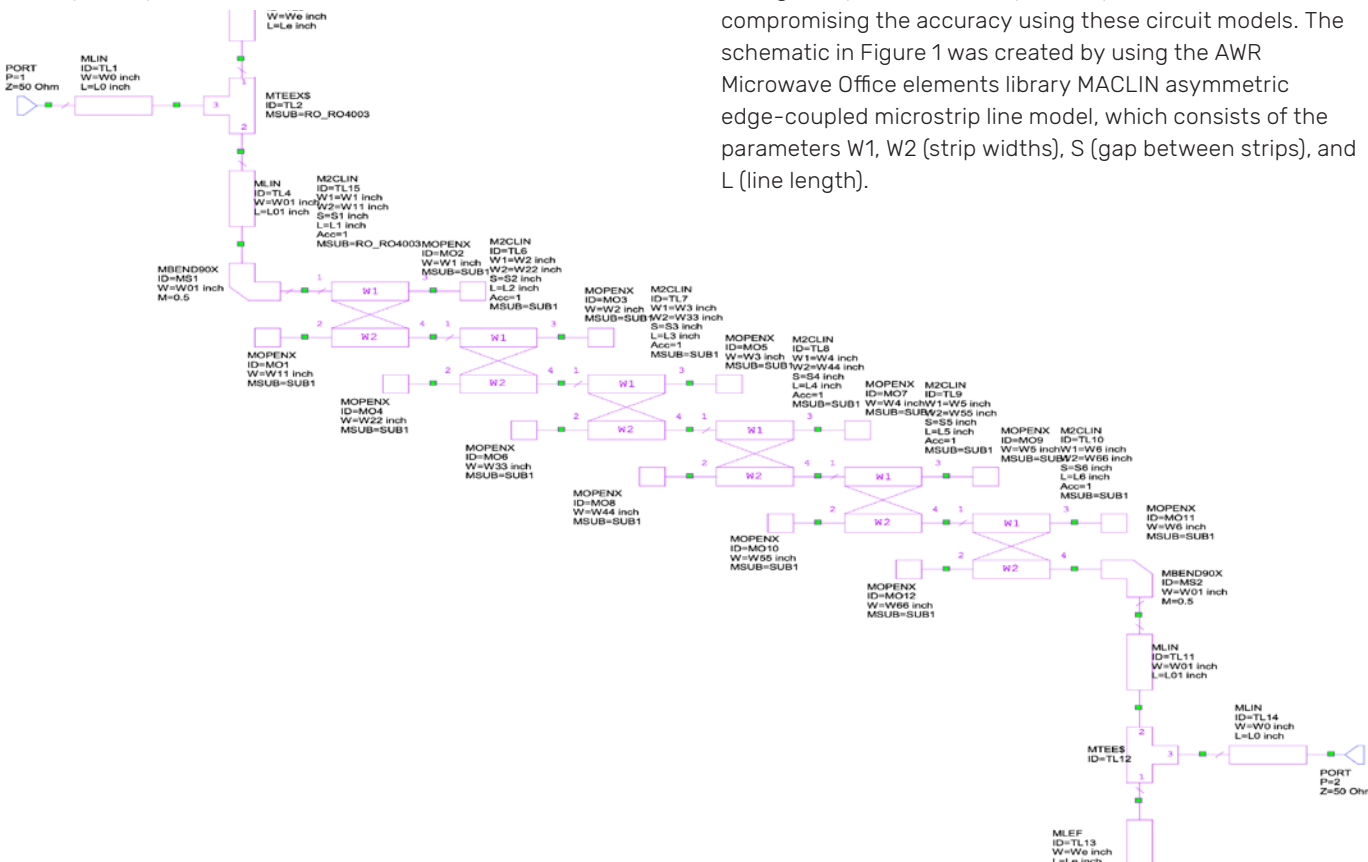

Figure 1: Layout of the BPF in AWR Microwave Office software.

## Simulation Model and Results

### Circuit Schematic Implementation

Models can be created for many basic components (transmission lines, coupled lines, MCROSSX, MTEEX\$, MSTEPX, and more). The electromagnetic (EM)-based X model elements and “S” based intelligent models were found to be more accurate compared to EM simulation. Simulation, tuning, and parameter sweeps were possible without compromising the accuracy using these circuit models. The schematic in Figure 1 was created by using the AWR Microwave Office elements library MACLIN asymmetric edge-coupled microstrip line model, which consists of the parameters W1, W2 (strip widths), S (gap between strips), and L (line length).

The final dimensions for the schematic design in the completed TX-LINE were  $W1 = 0.0121$  in.,  $W2 = 0.0124$  in.,  $W3 = 0.0124$  in., and  $W4 = 0.0124$  in. Figure 2 shows the integrated layout generation in AWR Microwave Office software, with the 2D representation on the left and the 3D representation on the right.

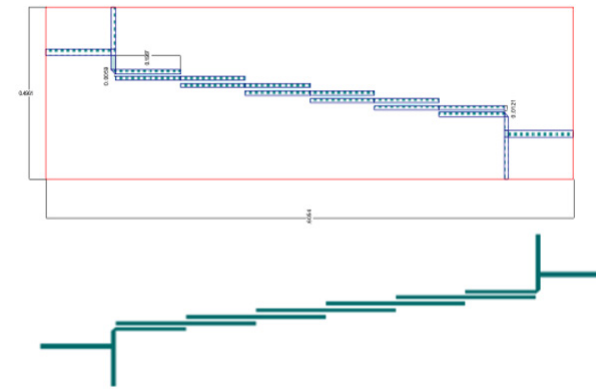

Figure 2: Edge-coupled BPF layout.

## Circuit Simulation Results

The circuit schematic was simulated in Microwave Office software based on the S-parameters. Figure 3 shows the results for insertion loss and return loss based on circuit analysis using the MACLIN asymmetric edge-coupled line models to define the filter network. The insertion loss in the frequency range of 8.4GHz to 9.3GHz was approximately 5dB with return loss well below 12dB. It can also be seen from the S-parameter results that the roll-off transition between the passband and stopband is relatively sharp, thus avoiding interference from adjacent channels (stopband rejection).

## EM Simulation

The AWR AXIEM planar method-of-moments (MoM) simulator within AWR Design Environment software was used to validate the BPF design. Once the EM simulations were carried out, the calculated current density can be annotated over the entire EM structure, which enables the designer to specify the frequency, phase, vector components, and color scaling associated with the magnitude of the current. It also supports the use of cut planes to enable designers to investigate current densities occurring within a more complex multi-layer structure through dissection of the PCB.

The EM simulation results in Figure 3 are shown in comparison to the circuit simulation results. The EM results were very similar to the circuit results and matched exactly the performance parameters with insertion loss in the frequency range of 8.4GHz to 9.3GHz with approximately 5dB and return loss well below 12 dB.

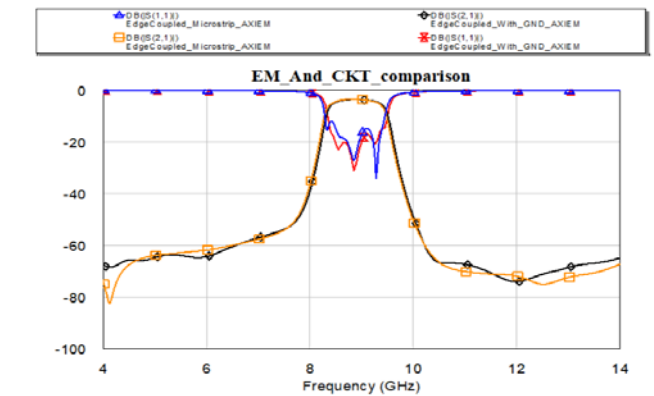

Figure 3: Comparison of circuit and EM simulation results (graph and table).

## Conclusion

A straightforward AWR Design Environment software design flow for a miniature X-band edge-coupled microstrip bandpass filter has been demonstrated. The simulated results showed good filter response characteristics with passband insertion loss of approximately 5dB and return loss greater than 12dB in the 900MHz bandwidth with a center frequency of 9GHz. The validation results using AWR AXIEM EM simulation were in good agreement with the circuit simulation results based on the edge-coupled transmission-line models available in Microwave Office software. The performance of this BPF design at this frequency range is suitable for aerospace/defense requirements for land, airborne, and naval radar applications.

# E-Learning Portal

## VSS RF Link Budget Analysis

This e-learning video series demonstrates how to use the AWR Visual System Simulator™ (VSS) software and its impedance-mismatch-aware, linear, and nonlinear RF/microwave behavioral models to perform budget analysis. These design tools are useful for system architecture development and RF component specification for communications system design.

- ▶ Part 1 – Build a basic RF link in AWR VSS using a behavioral filter model and how to replace it with an actual circuit model derived from Microwave Office circuit design software and the iFilter™ filter synthesis wizard
- ▶ Part 2 – Model a filter with the AWR VSS behavioral filter model
- ▶ Part 3 – Model a mixer with the AWR VSS powerful and intelligent mixer model
- ▶ Part 4 – Modulated signal passing through an RF link path and system metrics in the time domain like the eye diagram and spectrum plot, as well as EVM, ACPR, ACLR, and BER measurements

## Phase Noise Modeling in VSS

This e-learning video series explains how to use the AWR VSS time-domain engine to model phase noise in communications and radar system design. The three main forms of noise modeled in the AWR VSS program are thermal circuit noise, channel noise, and phase noise. Circuit noise and channel noise are both based on white Gaussian noise. Circuit noise is primarily specified as a noise temperature, a noise figure, or equivalent noise voltage or current sources. Channel noise is typically specified in noise power spectral density (noise PSD). RF budget analysis simulations primarily work with circuit noise, which is frequency dependent, although they also provide limited support for channel noise. Time domain simulations are most effective when modeling white channel noise.

- ▶ Part 1 – Setting up the system schematic to perform phase noise accurately to a very small offset from the carrier frequency
- ▶ Part 2 – Implementing phase noise simulation using a phase noise mask placed directly on the in-phase and quadrature signals from a 64-quadrature amplitude modulation (QAM) source driving a receiver to measure the error vector magnitude (EVM)
- ▶ Part 3 – Distinguishing the difference between correlated and uncorrelated noise in AWR VSS calculations

Learn more at [awr.com/elearning](http://awr.com/elearning).



# Resource Library

The resource library on [awr.com](http://awr.com) is a dedicated and searchable landing page for technical content on AWR software products, and solutions. Recent additions to the [resource library](http://awr.com) include:

## White Paper

- ▶ Design of a Complete RF Downconverter Module for Test Equipment

## Application Note

- ▶ Design and Implementation of a Miniature X-Band Edge-Coupled Microstrip Bandpass Filter

## Collateral

- ▶ PCB Design Leveraging RF/Microwave Expertise in Cadence AWR Software

## Articles

- ▶ LNA Receiver Design for Integrated Automotive Wireless Systems - High Frequency Electronics
- ▶ Together We Can Grow WIM: Show Up, Speak Up, Step Up - IEEE Microwave Magazine



# PCB Design Leveraging RF/Microwave Expertise

Designers face multiple challenges when incorporating RF/microwave, analog, and digital design elements together on the same printed circuit board (PCB). These multi-layer PCBs, which are commonly used in next-generation commercial and military applications, are densely populated with high-speed data lines and RF circuitry and are prone to coupling/crosstalk and other parasitic behavior that can impair system performance.

To successfully integrate RF/microwave content and mixed-signal designs, PCB layout tools and RF circuit design software must exchange design data efficiently. Cadence's AWR software offers an RF/microwave intellectual property (IP) creation platform with import and export functionality to provide a pathway to and from Cadence Allegro or OrCAD® PCB design tools (Figure 1).

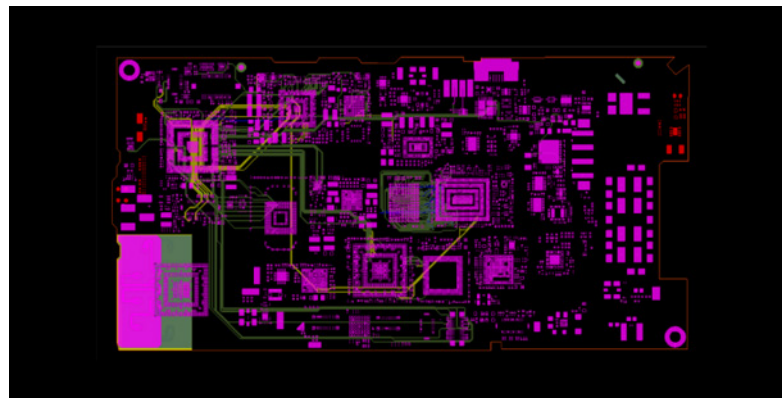

Figure 1: Cadence originated PCB imported into AWR software through an IPC-2581 file format.

## RF/Microwave IP Integration

RF/microwave designers use schematic capture to place active and passive components within a network. Unlike analog and digital designs, which use parasitic extraction after layout, these designs typically include closed-form transmission line models (such as microstrip and stripline) explicitly in the schematic to account for RF behavior much earlier in the design process. Electromagnetic (EM) analysis is also used to characterize structures and validate the overall design. In this way, the electrical and physical designs are concurrently implemented. The AWR Design Environment provides the platform for RF/microwave design entry, circuit/system/EM analysis, and optimization.

The result is an electrical design with the layout and PCB stackup information necessary to ensure accurate prediction of the manufactured device's performance. Transferring this layout and stackup information into the Cadence PCB layout and routing platform eliminates the need for manual design re-entry, thus saving time, costs, and the potential for errors.

### Features

- ▶ Linear/nonlinear frequency-domain simulation for RF/microwave circuit design
- ▶ Schematic-driven RF-aware design with integrated EM extraction technology
- ▶ Parametric studies with optimization, tuning, and yield analysis

### Benefits

- ▶ Reduce design time with a comprehensive workflow that supports data exchange between RF/microwave and PCB design tools
- ▶ Maximize engineering productivity with design automation and a user-friendly interface for engineers of all skill levels
- ▶ Eliminate costly design respins through accurate design verification

## RF/Microwave PCB Verification

RF/microwave PCB verification is enabled by importing an IPC-2581 file into AWR software through the AWR Microwave Office software PCB import wizard (Figure 2). Powerful editing features prepare the structure for fast, accurate, and efficient EM analysis using the AWR AXIEM planar EM simulator, which enables designers to select traces, layers, and board regions and specify exactly which layers, nets, and board areas to analyze. Designers can easily omit manufacturing details that won't impact electrical behavior but will unnecessarily slow down the simulation.

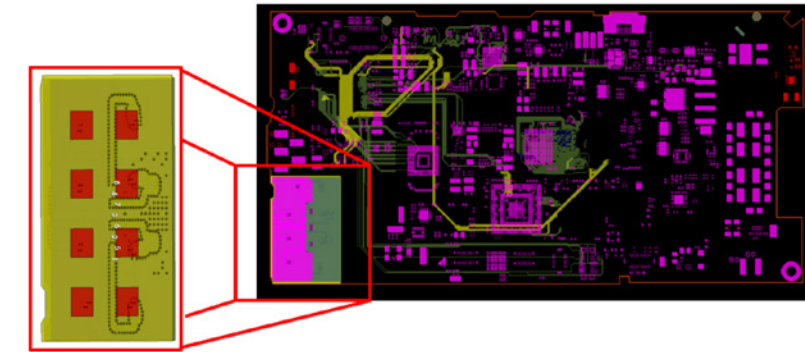

Figure 2: Integrated mmWave IP area on a mixed-signal PCB with antenna array in the red popout.

The AWR AXIEM simulator uses the method-of-moments (MoM) technique to analyze distributed PCB components, transmission lines, and layer-to-layer PCB interconnects like vias. Designers extract S-parameters directly and visualize fields/currents to identify parasitic coupling, resonances, and other concerns that could lead to design failure.

### Features

- ▶ Full-wave planar MoM technology with advanced hybrid adaptive meshing
- ▶ Time-saving PCB import wizard technology
- ▶ Layout editor with shape modifiers/de-featuring for fast EM simulation
- ▶ Field visualization and post-processing

### Benefits

- ▶ Reduce design time with a comprehensive workflow that supports data exchange between RF/microwave and PCB design tools
- ▶ Maximize engineering productivity with design automation and a user-friendly interface for engineers of all experience levels
- ▶ Eliminate costly design respins through accurate design verification

## Conclusion

At higher operating frequencies, the physical details of circuit components and signal traces will impact electrical performance and must be considered as part of the design process. Electronics can appear to behave in unpredictable ways at radio and microwave frequencies, often seeming to violate basic electrical principles such as Ohm's law. EM analysis based on layout and stackup information is commonly used by RF/microwave designers to understand how physical design impacts electrical behavior.

With RF-aware simulation tools, engineers eliminate wasted cycles trying to design and troubleshoot front-end components and related integration challenges. In addition, EM analysis plays a critical role in design verification of all high-speed mixed-signal traces. The state-of-the-art RF/microwave capabilities within Cadence's AWR software product portfolio help engineers ensure successful wireless design and integration.

# Design of a Complete RF Downconverter Module for Test Equipment

RF/microwave modules such as the 3D layout of a finished downconverter circuit shown in Figure 1, often referred to as “hybrids,” integrate functional blocks used to transmit and/or receive radio signals. These hybrid circuits combine different technologies, including monolithic microwave integrated circuits (MMICs)/RFICs, discrete field-effect transistors (FETs), and passive devices attached to substrates such as alumina or FR4, which contain circuit traces and distributed components, all within a single housing or enclosure.

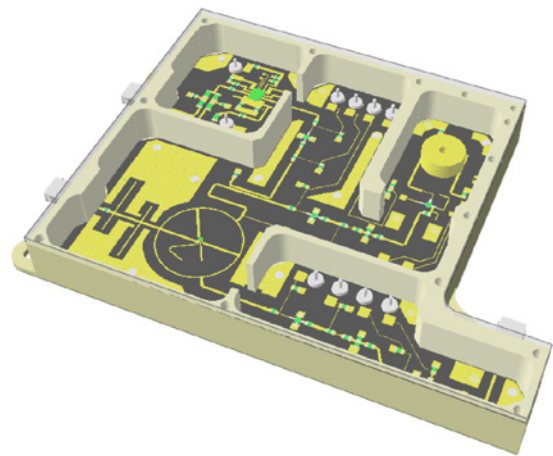

Figure 1: 3D layout of the finished downconverter circuit.

By integrating diverse technologies, RF modules address the challenge of developing cost-effective radio circuitry for low- to medium-volume production, commonly used in test and measurement equipment and aerospace/defense applications.

RF design is complicated by the sensitivity of radio circuits and the electrical behavior of components and layouts at higher frequencies. In addition to the electrical design, engineers must consider the manufacturing process to ensure that the RF performance is not adversely affected. Radio circuits are also subject to limits on radiated emissions, requiring conformance testing and certification by standardization organizations. For these reasons, a pre-made “drop-in” radio module that adheres to a specified footprint and input/output (I/O) connector configuration helps save the system/subsystem designer development time and money.

This white paper describes the design and simulation of a complete downconverter module for use in spectrum analyzer test equipment. The example module and its constituent parts were designed and simulated with AWR Design Environment software demonstrating a top-down/bottom-up approach using circuit- and system-level analyses. The integration of the downconverter within a mechanical outline influences the layout of the individual radio blocks. Electromagnetic (EM) simulation of the module housing along with these blocks is necessary to produce a comprehensive analysis of the manufactured module.

## Module Specification

A downconverter module consists of all the components in a receiver that process an incoming RF signal before conversion to a lower intermediate-frequency (IF) range for further processing. Performance parameters include input/output frequency range, conversion gain, noise figure (NF), input/output power, return loss, spurious tones, power consumption, number of channels, and operating temperature. In addition to these electrical requirements, the spectrum analyzer test equipment application requires a specific mechanical footprint and I/O connector positioning. The following example illustrates the high-level design and system analysis of the downconverter module within a spectrum analyzer front-end. Part of the RF front-end of the receiver is shown in Figure 2, with the downconverter module circled in red.

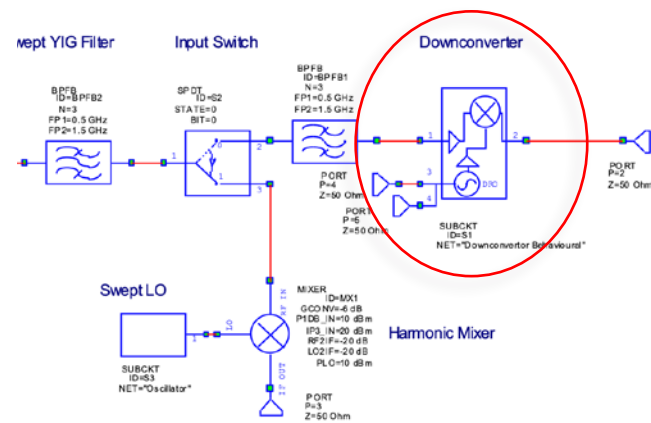

Figure 2: Spectrum analyzer front-end schematic showing downconverter receiver (in red circle).

The downconverter design is partitioned into blocks for amplification, including filtering, mixers, oscillators, buffer amplifiers, digital divider, and phase-locked loop (PLL) dynamics (Figure 3). Each block can be represented in simulation by a high-level behavioral model or detailed circuit level sub-circuit as that information becomes available to the design team integrating the individual radio blocks. Since it is often the case that each block will be developed by a different designer, it is critical that the module flow supports the analysis of all these designs assembled into a single project.

At the downconverter subsystem level, the performance was simulated using Cadence AWR Visual System Simulator (VSS) software. The AWR VSS behavioral and measured circuit-based models enable designers to perform budget, spectral, and time-domain analyses to aid in all phases of module development, from architectural studies to design verification. Cadence AWR Microwave Office software was used to develop the individual radio blocks in the downconverter, including all amplifier, filter, and mixer designs.

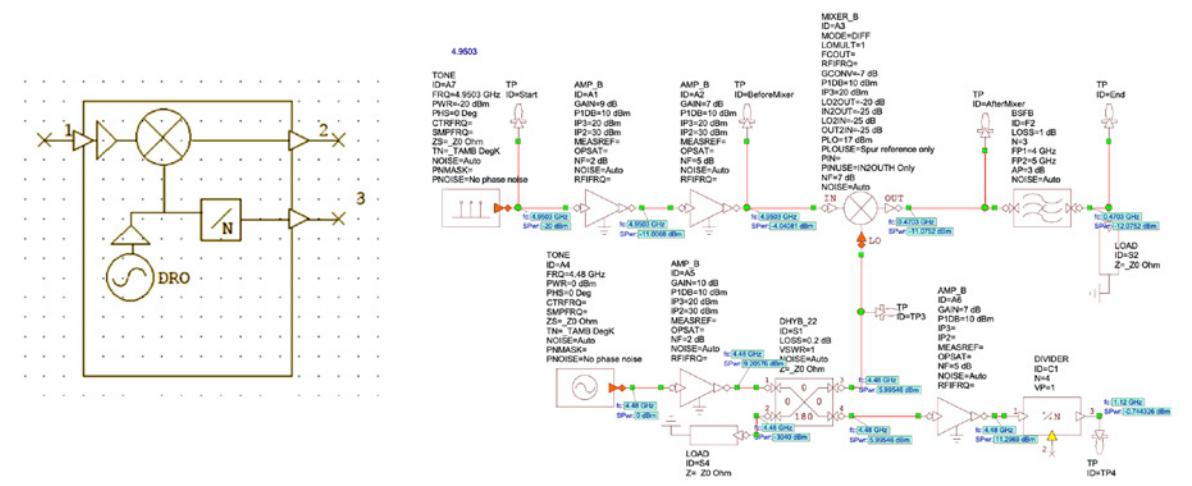

Figure 3: Top-level downconverter symbol in schematic editor and individual downconverter radio blocks defined with behavioral models.

## Downconverter Module Design

Once all the radio blocks are designed at the circuit level (not discussed are the passive coupler, DRO buffer, and divider), the entire downconverter can be assembled from these subcircuits into a single hierarchy for analysis, as shown in Figure 4. The electrical specification of the module requires conversion of microwave signals to a lower IF range, which can be investigated with circuit-level accuracy.

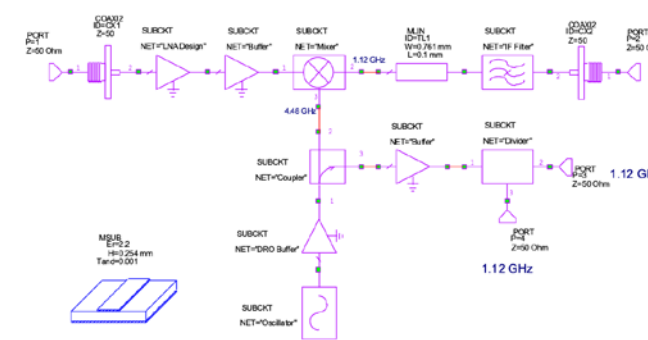

Figure 4: Complete downconverter module design with system-level behavioral models replaced with circuit-based models.

A final step in the overall design and verification of the downconverter prior to manufacturing may include the analysis of any potential interaction between the planar subcircuits and the 3D enclosure (housing). Enclosure resonances (modes) can be simulated using Cadence AWR Analyst™ EM software. The mechanical design was imported and analyzed with the Analyst Eigenmode solver, which can plot the fields and surface currents on the enclosure to help designers visualize potential trouble areas.

## Conclusion

RF/microwave modules integrate diverse technologies to address cost and performance concerns associated with low- to medium-volume wireless applications. This white paper has demonstrated the combined use of system-level analysis for design partitioning and component specification along with circuit-level simulation and EM analysis in the development of a complete hybrid downconverter.

To read the white paper in its entirety, visit [awr.com/resource-library/design-complete-rf-downconverter-module-test-equipment](http://awr.com/resource-library/design-complete-rf-downconverter-module-test-equipment).

# Anritsu Designs G-Band Frequency Tripler for Broadband Instrumentation

Broadband frequency sources are required to extend the frequency range of broadband microwave and millimeter-wave (mmWave) test equipment for applications such as 5G new radio (NR) communications, automotive radar, and security (detection) applications. In some broadband systems, nonlinear transmission line (NLTL)-based multipliers and receivers have been used to extend the frequency ranges. NLTL-based multipliers can be used to extend broadband system frequency ranges.



*The time it takes to figure out how to do something with Microwave Office software is far less than other circuit simulators on the market. It is the only circuit simulator Anritsu owns and uses.*

Jon Martens, Anritsu

However, the difficulty in meeting the input drive level and unwanted harmonic suppression requirements for NLTL devices motivated Anritsu designers to develop an extended planar frequency tripler covering the entire G-band (140-220 GHz). Cadence AWR software enabled them to 3D simulate the structure and extract an accurate representation of the six-port model that was critical to the success of the design.

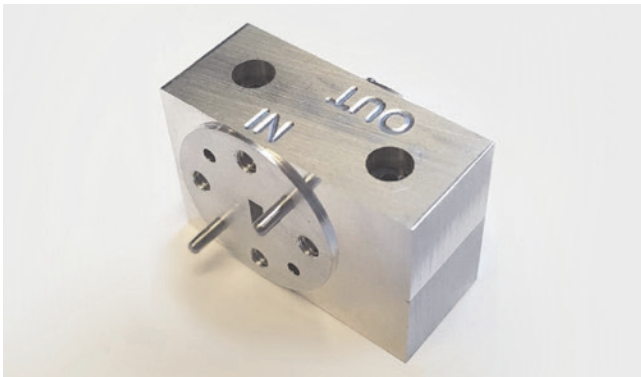

WR15-WR5 G-band tripler assembly.

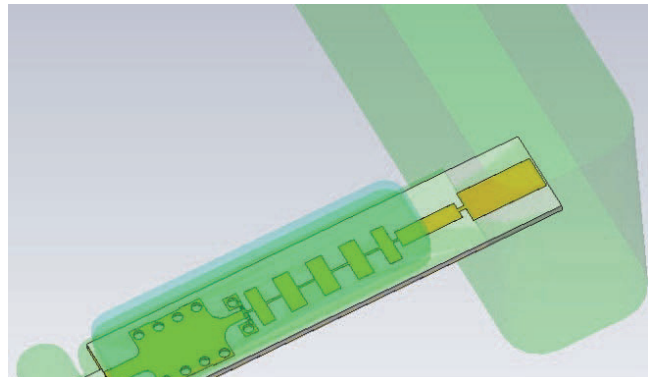

Complete 3D EM model of the G-band tripler.