

Design IP for USB 3.0 xHCI Host Controller

Overview

For over two decades, the Universal Serial Bus interface has truly lived up to its name—it has become the versatile connection standard that is present in a majority of electronic devices—laptops, mobile phones, and portable electronics. After years of industry ubiquity of USB 2.0, USB 3.0 applications are becoming the preferred option due to close to 10X better performance to handle the growth of data that is being transferred between devices.

Compliant with Universal Serial Bus 3.0 Specification, Revision 1.0 and xHCI Specification, Revision 1.0, the Cadence® Design IP for USB 3.0 xHCI Host Controller operates in SuperSpeed (5Gbps), High-Speed (480Mbps), Full-Speed (12Mbps), and Low-Speed (1.5 Mbps) modes. The PHY interface complies with USB PHY Interface for PCI Express® (PIPE) for USB 3.0, as well as the USB 2.0 Transceiver Macrocell Interface (UTMI+) specification.

Combined with the Cadence PHY IP for USB Type-C designs, the Controller IP provides a complete solution for the next generation of USB applications that will make use of the new, flexible USB Type-C connector.

The Controller IP is architected to quickly and easily integrate into any SoC as an integrated solution with any Cadence or third-party PHY IP for USB. Host applications access the controller through the industry-standard ARM® AMBA® AXI system bus. The Controller IP is part of the comprehensive Cadence Design IP portfolio comprised of interface, memory, analog, and system and peripheral IP.

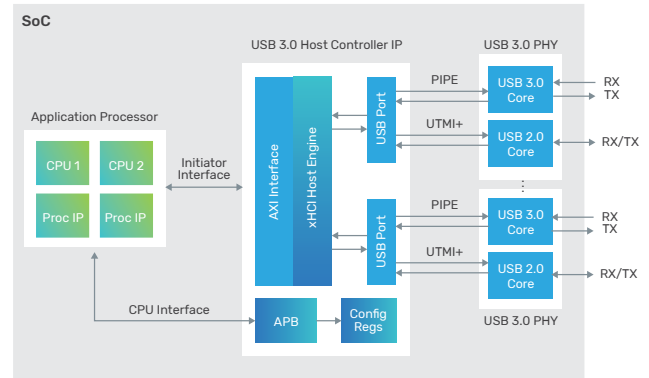

Figure 1: Example system-level block diagram

Benefits

- ▶ Support for all USB speeds—connect to every USB device
- ▶ Industry-standard interfaces—simple system integration
- ▶ Available as integrated solution—less time spent on verification

Key Features

- ▶ SuperSpeed (5Gbps), High-Speed (480Mbps), Full-Speed (12Mbps), and Low-Speed (1.5 Mbps) modes of operation
- ▶ Compliant with USB 3.0 and xHCI specifications
- ▶ Single-port USB 2.0 and USB 3.0
- ▶ AMBA 3 AXI Initiator system bus interface with support AXI features
- ▶ PIPE interface for USB 3.0 and UTMI+ for USB 2.0
- ▶ Ready for integrated delivery with the Cadence PHY IP for USB

Product Details

The Controller IP is aimed at providing SoC designers with the most robust way to implement a USB interface in their applications.

System Interface

The Controller IP features a 64-bit data/address AXI Initiator interface and a 32-bit data/address APB Responder interface. The AXI Initiator interface provides support for outstanding and out-of-order transactions.

Both AXI Initiator and APB Responder interfaces can operate at variety of frequencies to adjust to customer's application. Range of frequencies supported depends on the target SoC technology.

xHCI Host Engine

The xHCI Host Engine implements the DMA engine as defined by the xHCI specification. It uses a command ring to manage both xHC and all attached devices. Interrupts are realized through an event ring, which is handled by the xHCI Host Engine. The DMA engine of the xHCI Host Engine realizes transactions related with both command and event rings management.

Total count of supported devices influences the size of memory implemented in the xHCI Host Engine.

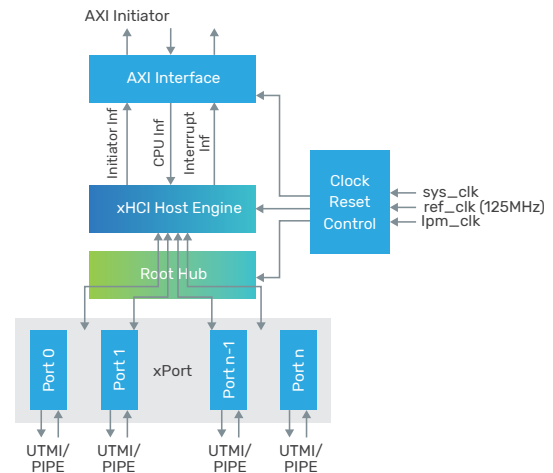

Figure 2: IP-level block diagram

Root Hub

The root hub implements two separate data paths for USB 3.0 and USB 2.0, respectively. It routes packets between USB ports and the xHCI Host module.

Root Ports (xPort)

The Controller IP connects to Cadence or third-party USB PHYs through the PIPE and UTMI+ interfaces for USB 3.0 and 2.0 speeds.

Availability

The Controller IP is available with support for the following protocol:

Protocol	Speed	Process node
USB 3.0	5 Gbps	All

Related Products

- ▶ PHY IP for USB 3.0
- ▶ PHY IP for USB Type-C
- ▶ Verification IP for USB Protocols

Deliverables

- ▶ Synthesizable RTL
- ▶ Delivery testbench
- ▶ Synthesis and simulation support files
- ▶ Documentation

For more information, visit cadence.com/designip.



Cadence is a pivotal leader in electronic systems design and computational expertise, using its Intelligent System Design strategy to turn design concepts into reality. Cadence customers are the world's most creative and innovative companies, delivering extraordinary electronic products from chips to boards to complete systems for the most dynamic applications. www.cadence.com

© 2022 Cadence Design Systems, Inc. All rights reserved worldwide. Cadence, the Cadence logo, and the other Cadence marks found at www.cadence.com/go/trademarks are trademarks or registered trademarks of Cadence Design Systems, Inc. All other trademarks are the property of their respective owners. J11181 09/22 SA/VY/PDF