

Denali High-Speed DDR PHY IP for TSMC 22ULP

Overview

Today's consumers generate and consume large volumes of data and video, exploding the required capacity and bandwidth for device memory. The Cadence® Denali® DDR family of high-speed interface IP connects to external memories with the necessary bandwidth for applications. The Cadence Denali High-Speed DDR PHY IP provides low latency and up to 3200Mbps throughput, while balancing power consumption and minimizing area

Developed by experienced teams with industry-leading domain expertise and extensively validated with multiple hardware platforms, the DDR PHY IP is silicon-proven and can provide customers with ease of integration and faster time to market. The DDR PHY IP is engineered to quickly and easily integrate into any system-on-chip (SoC), and is verified with the Denali DDR controller IP as part of a complete memory subsystem solution. The DDR PHY IP is designed to connect seamlessly and work with a third-party DFI-compliant memory controller.

The DDR PHY IP is developed and validated to reduce the risk for the customer so that their SoC can be first time right. Developed for and available early in the lifecycle of the most advanced semiconductor process nodes, the DDR PHY IP is designed to be robust under varying noise conditions and to have interoperability with various supplier memory chips.

The DDR PHY IP is part of the comprehensive Cadence Design IP portfolio comprised of an interface, Denali memory interface, analog; and systems and peripherals IP.

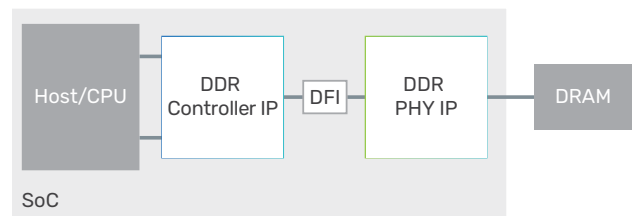

Figure 1: Example system-level block diagram

Benefits

- ▶ Lowest latency for data-intensive applications
- ▶ Highest data rates with detailed system guidelines
- ▶ Maximum system margin with advanced clocking and I/O architectures while reducing power and area

Product Details

The DDR PHY IP consists of a DFI interface to the memory controller, external register interface (configuration and test), PHY control block (initialization and calibration logic), and configurable data slices.

The DDR PHY IP is a high-performance DQS-delay architecture that uses programmable clock delay lines to align write data, read data capture, and DQS gating from the I/O pads across the DFI interface to the memory controller.

Key Features

- ▶ LPDDR4/LPDDR3/DDR4/DDR3/DDR3L training with write-leveling and data-eye training
- ▶ Memory controller interface complies with DFI standards 4.0 or 3.1
- ▶ I/O pads with impedance calibration logic and data retention capability
- ▶ Programmable clock delay (PVT compensated) on read and write datapaths for DQS alignment
- ▶ Optional clock gating available for low-power control
- ▶ Internal and external datapath loopback modes
- ▶ Multiple PLLs for maximum system margin
- ▶ Per-bit deskew on read and write datapath

PHY Architecture

To optimize the DDR interface the implementation, the DDR PHY IP provides complete flexibility with process, library, floorplan, I/O pitch, packaging, metal stack up, routing, and other physical parameters.

The DDR PHY IP is implemented with a slice-based architecture that supports a wide range of memory classes and data rates.

Data Slice and Address/Control Slices

The data slice is an 8-bit wide design that interfaces to the DQ, DM, and DQS connections of the DRAM. The data slice is duplicated to create the appropriate data width, allowing flexibility to adjust to meet the data-width requirements of the systems or applications.

The address and address/control slices interface to the control, command, and address connections of the DRAM. The address and address/control slices are duplicated to create the appropriate width for different protocols or combination of protocols, allowing flexibility to adjust the number of control, command, and address signals as needed.

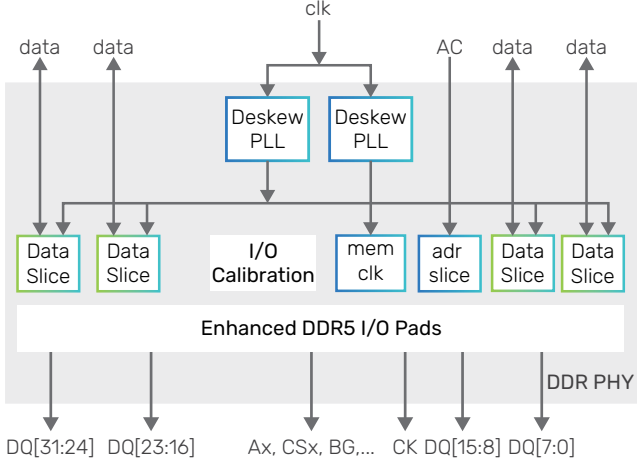

Figure 2: IP-level block diagram

External Register Interface

The external register interface is a Cadence-proprietary interface to access the data slice registers.

PHY Control Block

The HS PHY control block provides initialization and calibration logic for training the DQS alignment for each data slice.

Availability

The Cadence IP for DDR PHY IP is available with various configurations and supports the following protocols:

Protocol	Speed	Process Node
LPDDR4, LPDDR3	HS-3200	TSMC 22ULP
DDR4, DDR3, DDR3L	HS-3200	TSMC 22ULP

Related Products

- ▶ Cadence Denali Controller IP for LPDDR 4/3/2
- ▶ Cadence Denali Controller IP for DDR 4/3/2
- ▶ Cadence Verification IP for Memory Models 3L

Deliverables

- ▶ GDS II macros with abstract in LEF
- ▶ Verilog post-layout netlist
- ▶ STA scripts for use at chip or standalone PHY levels
- ▶ Liberty timing model
- ▶ SDF for back-annotated timing verification
- ▶ Verilog models of I/O pads, and RTL for all PHY modules
- ▶ Verilog testbench with memory model, configuration files, and sample tests
- ▶ Documentation, including integration and user guide, release notes
- ▶ Verification IP set-up files

For more information, visit cadence.com/designip.



Cadence is a pivotal leader in electronic systems design and computational expertise, using its Intelligent System Design strategy to turn design concepts into reality. Cadence customers are the world's most creative and innovative companies, delivering extraordinary electronic products from chips to boards to complete systems for the most dynamic applications. www.cadence.com

© 2022 Cadence Design Systems, Inc. All rights reserved worldwide. Cadence, the Cadence logo, and the other Cadence marks found at www.cadence.com/go/trademarks are trademarks or registered trademarks of Cadence Design Systems, Inc. All other trademarks are the property of their respective owners. J11418 10/22 SA/VY/PDF